



e.xact DP / IP

High Performance Multi-Function Test Controller

The e.xact features dynamic and precise measurements, fast signal conditioning, analog outputs for control, as well as standard communication interfaces.

All PAC features like fast PID control, state machines, and high speed data logging is another reason to use an e.xact in high speed measurement / control applications.

As a stand alone solution or as part of a large e.bloxx test stand project the e.xact adds data capabilities 10 kHz class.

4 x multi-conditioning analog inputs

10 kHz sampling rate/channel for voltage, current or bridge measurement

4 x analog outputs

Update rate of 10 kHz/channel

16 Mbytes measurement data buffer

Storage of measurement and conditioned data

Configurable and programmable PAC functionality

Easy application setup and programmability via e.con software

Fast data acquisition, conditioning and buffering

10 kHz: Measurement, scaling, storing, analog output

5 kHz: Signal conditioning, mathematics, data output via Ethernet

2.5 kHz: PAC functionality like PID, sequencing and advanced conditioning

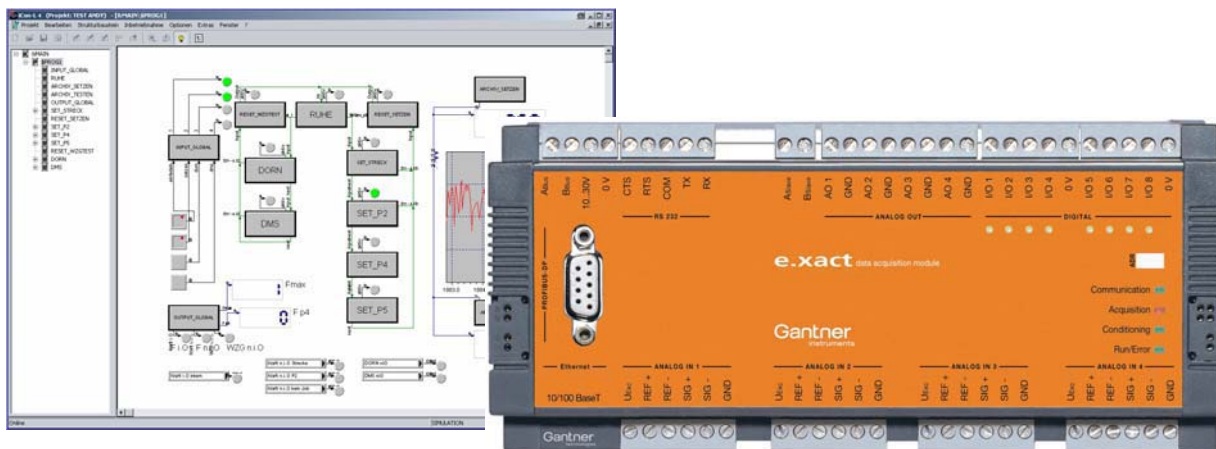

Order Information:

Product	Article No.
e.xact DP	438785
e.xact IP	440071

Accessories

Graphic programming system	
e.con Advanced	304373
e.con Lite	438987

Configuration software

e.commander	234476
-------------	--------

Patch cabel Ethernet cross	496524
----------------------------	--------

Additional Features

- Profibus-DP with up to 12 Mbps (e.xact DP only)
- Ethernet with 10/100 Mbps, FTP, TCP/IP, UDP
- 1 x RS 485 slave-interface for connection of e.bloxx modules
- RS 232 and RS 485 host interface
- 16 MByte divisible measurement storage
- Time stamp for all measurement values
- Synchronization with external modules (maximal 20 μ s Jitter)
- Power supply 10 to 30 VDC
- DIN rail mounting (DIN EN 50022 rail)
- Electromagnetic compatibility according to EN 61000-4 and EN 55011



e.xact DP /IP

Technical Data

High Performance Multi-Function Test Controller

Analog Input (4 per module)

Accuracy	0.01 % typical 0.02 % in controlled environment ¹ 0.05 % in industrial area ²		
Repeatability	0.003 % typical (within 24 h)		
Measurement	Range	Accuracy	Resolution
Voltage	±10 V ±2 V	±2 mV ±0.4 mV	40 µV 8 µV
Current (internal shunt 100 Ω)	±20 mA	±4 µA	80 nA
Bridge (Supply 5 VDC/120 Ω)	±5 mV/V	±5 µV/V	0.2 µV/V
Input resistance	> 10 MΩ		
Linearity deviation	0.01 % of the final value		
Signal to noise ratio	voltage measurement		
1 kHz	90 dB		
1 Hz	120 dB		
Temperature influence on zero	10 µV / 10 K (at ±10 V range) 0.2 µA / 10 K (at ±20 mA range) 0.1 µV / 10 K (at ±2.5 mV/V range)		
on sensitivity	0.02 % / 10 K		
Long-time drift	1 µV / 24 h; 0.1 µA / 24 h		

Analog/Digital Conversion

Resolution	19 bit
Sampling rate	10,000 samples/sec
Conversion method	Sigma-Delta

Analog Output (4 per module)

Type	Voltage output
Range	±10 VDC
Accuracy	±2mV
Resolution	±0.3mV
Valid load resistance	>5 kΩ
Temperature influence on zero	2 mV / 10 K
on sensitivity	0.05 % / 10 K
Noise voltage in range	
0 ... 10 Hz	2 mV
0 ... 1000 Hz	10 mV
Long time drift	1 mV / 48 h
Linearity deviation	0.01 % of final value
Resolution	16 bit
Refresh rate	10,000 samples/sec each channel
Settling time	100µs
Frequency response	2 kHz (-3 dB) each channel

Digital In/Output

Function	Power, watchdog, buffer handling, trigger, synchronization, zeroing
Inputs	
Input voltage	max. 30 VDC
Input current	max. 1.5 mA
Upper switching threshold	>3.5 V (high)
Lower switching threshold	<1.0 V (low)
Outputs	
Type of output	Open-Collector
Output voltage	max. 30 VDC
Output current	max. 100 mA

Slave-Interface RS 485

Standard	RS 485, 2-wire
Data format	8E1
Protocols	Gantner Local-Bus
Baud rate	9.6 kbps up to 6 Mbps
Connectable devices	max. 32

Host-Interface RS 232

Data format	8E1, 8O1, 8N1
Protocols	ASCII, Modbus RTU (parts)
Baud rate	9.6 kbps up to 115.2 kbps
Connection	RX, TX, COM, RTS, CTS

Host-Interface Ethernet

Protocols	TCP/IP, UDP, PING, ASCII, Modbus TCP/IP
Services	DHCP, FTP-Server
Baud rate	10/100Mbps
Number of simultaneous Clients	max. 10

Host-Interface Profibus-DP (e.xact DP only)

Standard	RS 485
Data format	8E1
Baud rate	9.6 kbps up to 12 Mbps
Connectable devices	max. 32

Host-Interface RS 485

Data format	8E1, 8O1, 8N1
Protocols	ASCII, Modbus RTU (parts)
Baud rate	9.6 kbps up to 115.2 kbps
Connectable devices	max. 32

¹ according to EN 61326: 1997, appendix B

² according to EN 61326: 1997, appendix A



e.xact DP / IP

Technical Data

High Performance Multi-Function Test Controller

Connection

Plug-in screw terminals	wire cross-section up to max. 1.5 mm ²
Profibus-DP	Sub-D9 plug
Ethernet	RJ 45 plug

Power Supply

Power supply	10 to 30 VDC over voltage and overload protection
Power consumption	approx. 5 W

Mechanical

Case	Aluminum and ABS
Dimensions (W x H x D)	190 x 90 x 83 mm (7.48 x 3.54 x 3.27 in)
Weight	500 g (1.10 lb)
Protection system	IP20
Mounting	DIN EN rail

Environmental

Operating temperature	-20 °C to +60 °C
Storage temperature	-40 °C to +85 °C
Relative humidity	5 % to 95 % at 50 °C non condensing

Performance Note:

The actual measurement and conditioning rate depends on the complexity of the application. The following information is for reference purposes.

10,000 measurements/sec

Measuring, A/D conversion, scaling as well as the analog outputs are handled in a FPGA and run with a speed of 10,000 Hz. The frequency response analog input to analog output is 2,000 Hz / channel. All data can be logged in the internal data buffer of 16 MByte. With the maximum rate of 10,000 measurements/s 4 channels can be recorded over a time of more than 1:40 min (depends on data format).

5,000 measurements/s

Further signal conditioning like configurable filter, mathematics, minimum/maximum, envelope curve or RMS are operated in the e.xact with a speed of 5,000 measurements/s. This is also the possible rate to read out data with FTP via Ethernet TCP/IP.

2,500 measurements/s

The PAC functionality like PID controlling, running a state machines or very advanced signal conditioning programmed with the graphical tool e.con will run with 2.500 measurements/s.

Typical applications:

Dyno Control

Here the e.xact is used for 3 PID loops in controller for brakes used in engine test bed. Various configuration settings can be performed by digital input, connected to a host system via Profibus/Modbus or PC via Ethernet.

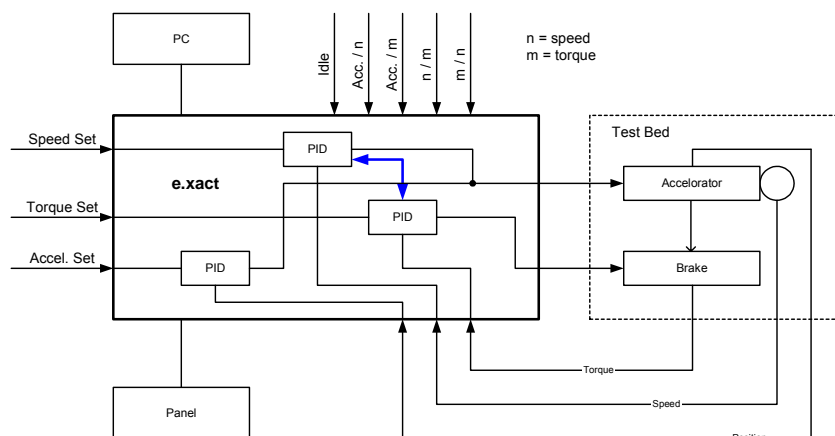

Loop cycle for data acquisition and output is 2.5 kHz. PID control's loop cycle is 1 kHz. With e.con programming software the functionality can be adapted to the exact need of the application. The result is a highly flexible solution for evaluating α vs. speed, α vs. torque, speed vs. torque etc.



Test Stand for Hydraulic Components

The test profile (time dependent pressure load) will be generated from the e.xact and provided to an actuator. The pressure p1 and p2 as well as the relevant displacements s1 and s2 of the valve have to be recorded to get a displacement/pressure diagram. The pressure p1 is also be used to control the PID in the e.xact.

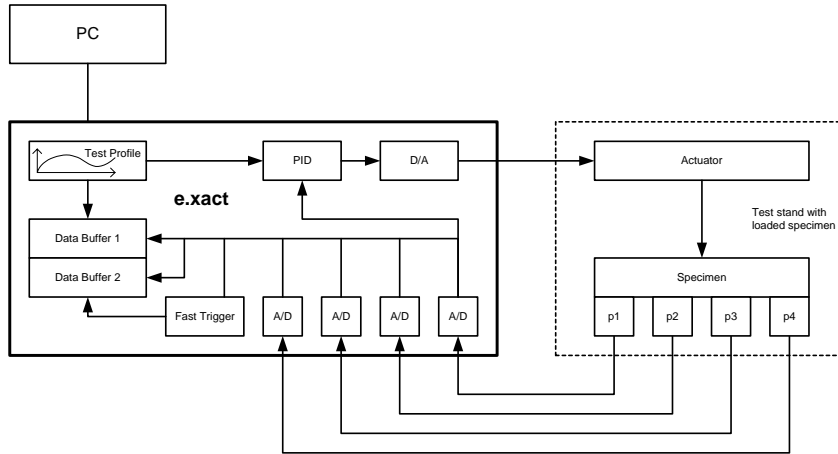

During the test Data Buffer 1 will record the measurements at a sample rate between 100 and 1000 samples/sec, controlled by the profile generator. If one of the measurements exceeds the preset limits, Data Buffer 2 will record the signals for a period of 10 s with a sample rate of 2000 sample/sec. After the test, the entire test file will be loaded into the PC.

Dynamic Controlling of the Centricity of a Moulding Press

To reach a constant high quality in a moulding press the force in all columns has to be dynamically measured and controlled. An online calculation of the resulting force and the coordinates of it center will avoid a non-centric pressing. Here the e.xact monitors tolerance limits and dynamically changes the pressure to each hydraulic column to balance pressure. Also, the resulting force and the x/y coordinates are stored for statistical process control purposes.

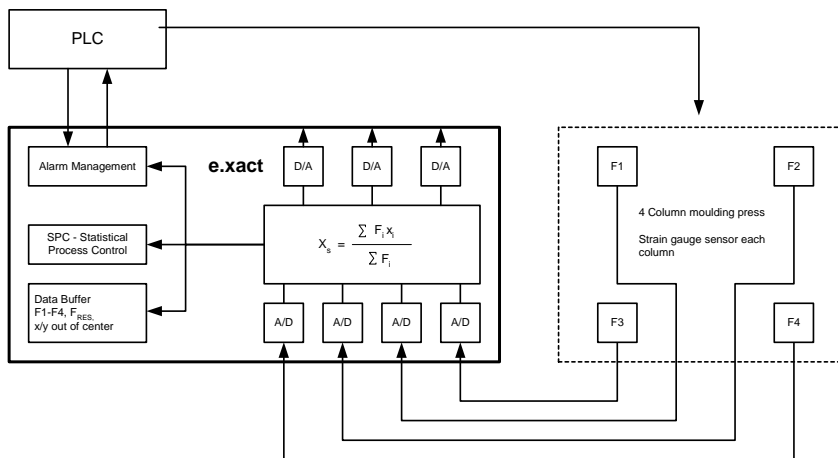

The dynamic online center monitoring is also usable for various loading processes with aircrafts, for tilt protection on platforms, or in many construction applications.

Valid from October 2006. Specification subject to change without notice